

Lodes *Preview* North America

ed. 2023

# LODES

2023 Preview

Part 1–New Concept Elara *design by* Nika Zupanc and Hover *design by* YOY Studio

Part 2–New Finish on Glass Random and Random Solo *design by* Chia–Ying Lee.

Lodes, via Pialoi 32,  
30020 Marcon (Venezia) Italy  
T +39 041 45 69 266  
info@lodes.com – lodes.com

2023 Preview

from *Venice* since 1950

New Concept: *Elara* NEW LAMP

01



New Concept: *Hover* NEW LAMP

02



New Finish: *Glossy Bronze*

03

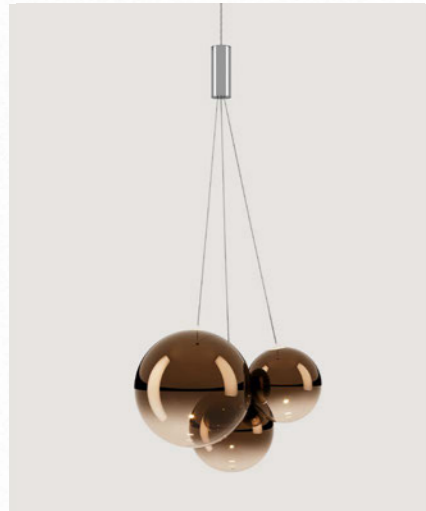

04



# 2023 Preview

Part 1–New Concept

06–37

01

*Elara*  
*design by* Nika Zupanc  
Suspension lamp

08

02

*Hover*  
*design by* YOY Studio  
Floor lamp, Table lamp

24

Part 2–Finishes

38–52

03

*Random*  
*design by* Chia–Ying Lee  
Cluster suspension lamp

41

04

*Random Solo*  
*design by* Chia–Ying Lee  
Cluster suspension lamp

47

## Nika Zupanc



After graduating with honour in 2000 at the *Academy of Fine Arts and Design*, Department of Industrial design in Ljubljana, the Slovenian product and interior designer *Nika Zupanc* became a globally recognised name with the launch of her first object in 2007. In 2008, she established her own eponymous studio in her hometown of Ljubljana and since works as an independent designer constantly involved in projects that grow out of distinctive interpretations of modern culture, contemporary design and available technological options.

Her products are part of the range of distinguished design companies and she works with prestigious clients on specially assigned commitments. Her praised limited edition collections and installations are exhibited around the world, sometimes as part of high-end collaborations like those with *Rossana Orlandi Gallery* in Milano. Along the way, Zupanc continuously produces objects under her own brand *Nika Zupanc* and is involved in various projects and collaborations. Elsewhere, she has continued to build her portfolio to rising acclaim also with curated solo-and-group exhibitions around the world.

In the last few years, Zupanc has become one of the most closely-watched designers at Milan Design Week: not just for her stand-alone products but also for her installations. In 2020 she designed an extensive collection of furniture for Natuzzi Italia and she received the 2020 Archiproducts Design Awards in the Furniture category for the Wave sofa, a central piece to the collection.

Her visual language comes from deep within and is about “communicating the things that cannot be told.”

Dopo essersi laureata con lode nel 2000 presso *Academy of Fine Arts and Design*, in Industrial Design a Lubiana, la product e interior designer slovena *Nika Zupanc* è diventata un nome riconosciuto a livello mondiale con il lancio del suo primo oggetto prodotto su larga scala nel 2007. Nel 2008 ha fondato l'omonimo studio nella sua città natale, Lubiana, e da allora lavora come designer indipendente, costantemente coinvolta in progetti che nascono da interpretazioni distintive della cultura moderna, del design contemporaneo e delle varie tecnologie disponibili.

I suoi prodotti fanno parte del portfolio di rinomati brand di design e collabora con clienti prestigiosi su progetti speciali. Le sue collezioni e installazioni in edizione limitata sono esposte in tutto il mondo, talvolta nell'ambito di collaborazioni di alto livello come quella con la *Galleria Rossana Orlandi* di Milano. Nel frattempo, Zupanc produce continuamente oggetti con il proprio marchio *Nika Zupanc* ed è coinvolta in vari progetti e collaborazioni. Inoltre, ha continuato a costruire il suo portfolio, riscuotendo un crescente successo anche con mostre personali e collettive curate in tutto il mondo.

Negli ultimi anni, Zupanc è diventata una delle designer più seguite durante la Milano Design Week: non solo per i suoi prodotti, ma anche per le sue installazioni. Nel 2020 ha progettato un'ampia collezione di arredi per Natuzzi Italia e ha ricevuto il premio Archiproducts Design Awards 2020 nella categoria Furniture per il divano Wave, pezzo centrale della collezione.

Il suo linguaggio visivo nasce dal profondo e si propone di “comunicare le cose che non possono essere raccontate”.

### Product

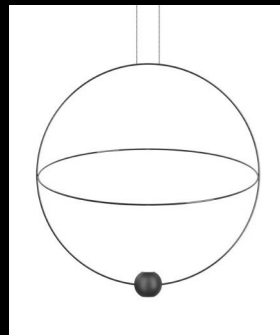

Elara  
► Suspension lamp  
pag. 08

## YOY Studio



Established in 2011, YOY is a design studio by Naoki Ono and Yuki Yamamoto, based in Tokyo and working internationally. They design mainly furniture, lighting and interiors around the theme of “between space and objects”.

YOY specialises in designing products that tell short stories of everyday life, such as “Canvas”, a canvas with a drawing of a chair, which doubles as a chair by leaning against a wall, and “Scribble”, a series of table mats that look like scribbles. The products pursue aspects of design that go beyond ease of use and functionality.

YOY first presented their independent works at Milan Design Week 2012 and have since participated in the event for eight consecutive years. Their works have now been commercialized by European and American brands.

They have held exhibitions including “Fictionality”, which featured works that infuse fiction into everyday life, and “Existence”, which focused on themes of human nature, perception and existence.

Their works are sold all over the world including MoMA, and they have received several international awards.

Fondato nel 2011 da Naoki Ono e Yuki Yamamoto, YOY è uno studio di design con sede a Tokyo e operante a livello internazionale. Il tema centrale che caratterizza il loro design, è l'analisi del rapporto “tra spazio e oggetto” nel progettare arredi, illuminazione e spazi interni.

YOY è specializzato nella progettazione di prodotti che raccontano brevi storie di vita quotidiana, come “Canvas”, una tela con il disegno di una sedia, che si trasforma in una sedia appoggiata al muro, e “Scribble”, una serie di tovagliette che sembrano scarabocchi. I prodotti perseguono aspetti del design che vanno oltre la facilità d'uso e la funzionalità.

Gli YOY hanno presentato per la prima volta i loro lavori indipendenti alla Milano Design Week del 2012 e da allora hanno partecipato all'evento per otto anni consecutivi. I loro lavori sono stati messi in vendita da brand europei e americani.

Hanno organizzato mostre come “Fictionality”, che presentava opere che infondono finzione nella vita quotidiana, e “Existence”, incentrata sui temi legati alla natura umana, alla percezione e all'esistenza.

I loro lavori sono venduti in tutto il mondo, incluso il MoMA, e hanno ricevuto numerosi premi internazionali.

### Products



Hover  
► Floor lamp  
pag. 24

Hover  
► Table lamp  
pag. 24

# New Concept: Elara

Part 1-New Concept: Elara medium



● Black

○ Gold

Elara large



● Black

○ Gold

# Elara

The name Elara connotes astronomy and Greek mythology, and its geometric design mimicks the trajectory of the planets within the universe. Inspired by astral motion, the lamp is characterised by two metal rings, one of which can be set at various angles to produce fluidity and movement, as well as a small sphere at the bottom of the lamp that contains the light source.

The central ring can be positioned to reach different heights and angles, allowing users to experiment with casting light and shadows. Elara features a dimmer controlled with the wall-mounted power switch, allowing users to modulate the intensity of the light to create their ideal lighting scheme.

Available in two sizes, medium (Ø 60 cm) and large (Ø 80 cm), Elara suits a range of environments, such as over a dining table in a residential setting, or as part of a larger installation in public spaces like a hotel lounge or restaurant.

Il nome Elara richiama l'astronomia e la mitologia greca, e il suo design geometrico imita la traiettoria dei pianeti nell'universo. Ispirata al movimento astrale, la lampada è caratterizzata da due anelli metallici, uno dei quali può essere posizionato a varie angolazioni per produrre fluidità e movimento, e da una piccola sfera all'estremità inferiore della lampada che contiene la sorgente luminosa. L'anello centrale può essere posizionato in modo da raggiungere diverse altezze e angolazioni, consentendo agli utenti di sperimentare la proiezione di luci e ombre. Inoltre, Elara è dimmerabile mediante dimmer comandato dall'interruttore a parete, che consente di modulare l'intensità della luce per creare il proprio schema di illuminazione ideale.

Disponibile in due dimensioni, medium (Ø 60 cm) e large (Ø 80 cm), Elara si adatta ad una vasta gamma di ambienti, come ad esempio sopra un tavolo da pranzo in un ambiente residenziale, o come parte di un'installazione più grande in spazi pubblici come la lounge di un hotel o un ristorante.

## Suspension lamp

Elara medium and large,  
FINISHES Black and Gold

Elara, *design by* Nika Zupanc, 2022





Elara medium and large,  
FINISHES Black and Gold

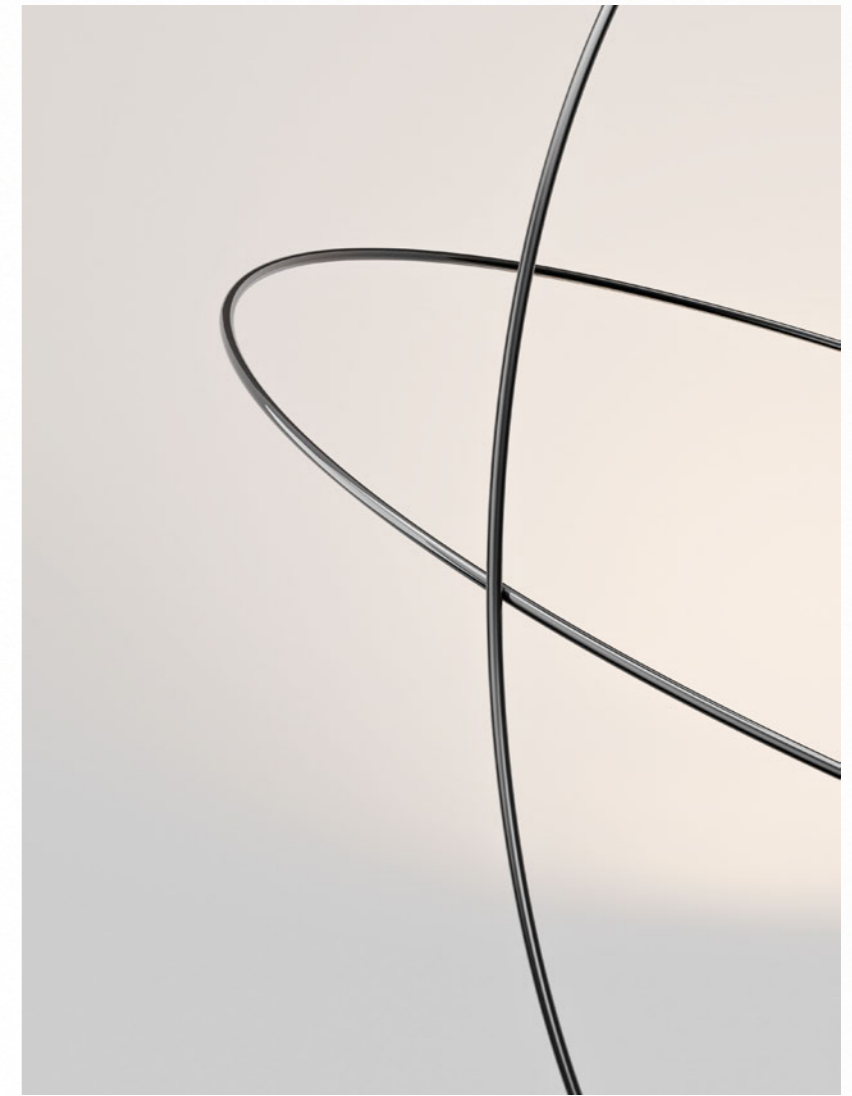

Elara, metal rings, FINISH Glossy Black

Elara large, FINISH Black



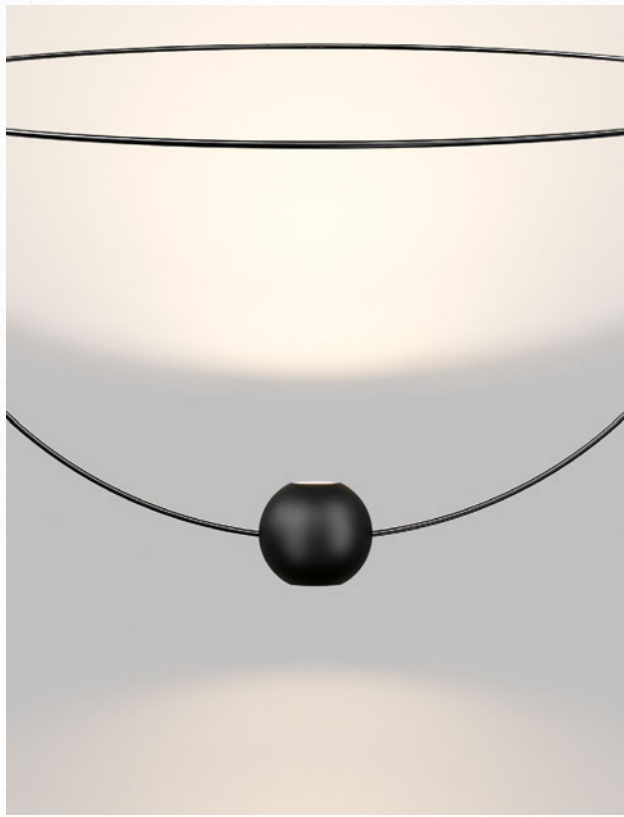

1

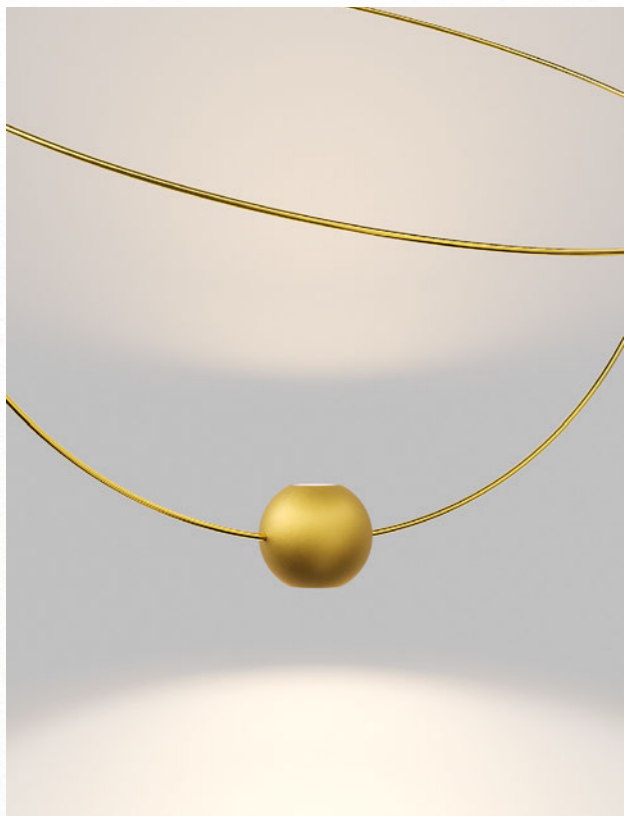

2

1–Metal sphere, side I (up)  
side II (down), FINISH Extra Matte Black  
2–Metal sphere, side I (down)  
side II (up), FINISH Matte Gold

Elara large, FINISH Black



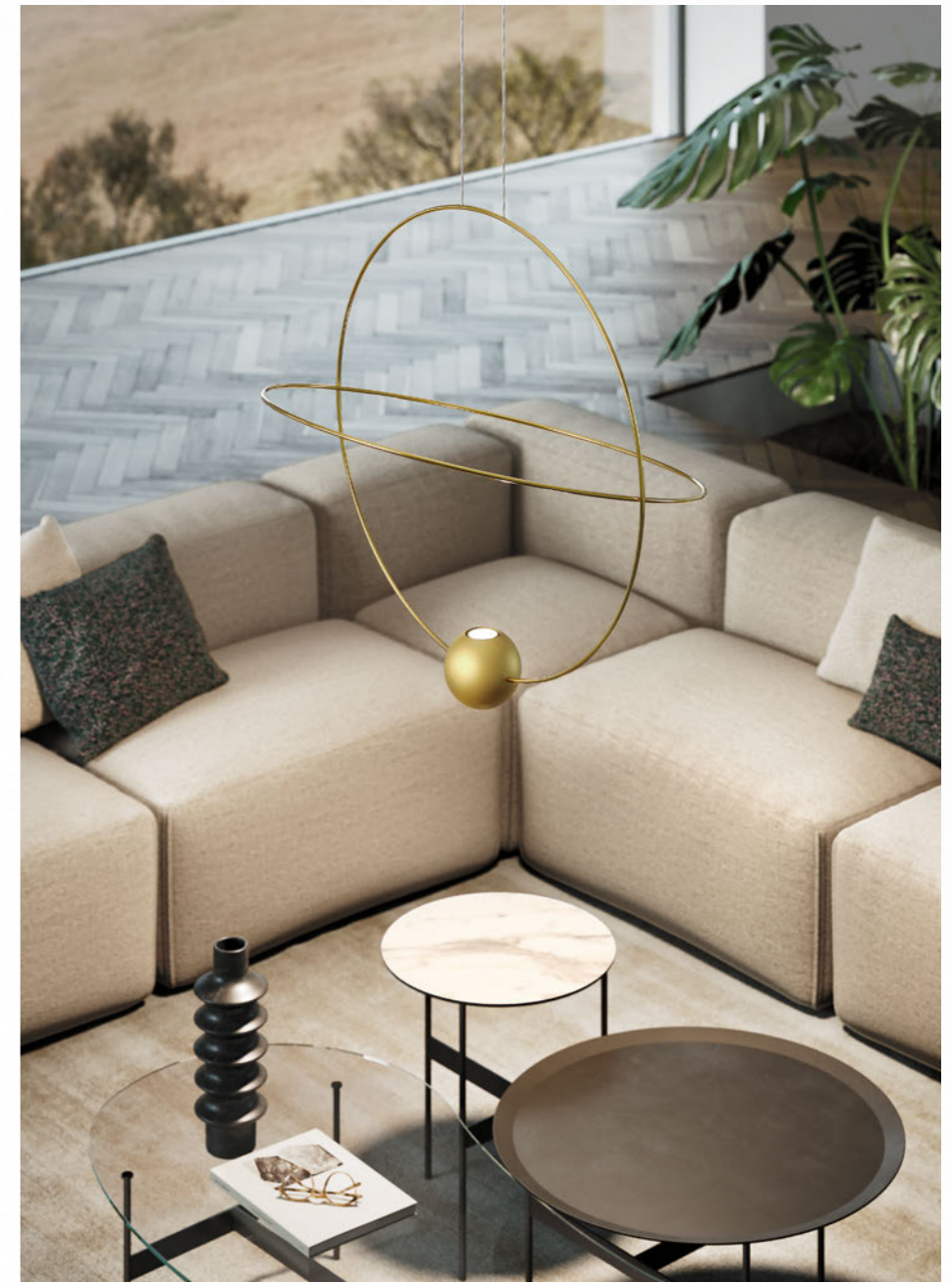

Elara medium, FINISH Gold



Elara large, FINISH Gold



Elara is characterised by two metal rings, one of which can be set at various angles

Le nom Elara évoque l'astronomie et la mythologie grecque, et son design géométrique la trajectoire des planètes dans l'univers. S'inspirant du mouvement astral, la lampe se caractérise par deux anneaux métalliques : un pouvant être positionné à différents angles, créant ainsi fluidité et mouvement, et par une petite sphère à l'extrémité inférieure de la lampe qui abrite la source lumineuse. L'anneau central peut être positionné pour atteindre différents angles et hauteurs, permettant aux utilisateurs d'expérimenter la projection de lumière et d'ombre. De plus, Elara est dimmable au moyen d'un gradateur contrôlé par l'interrupteur mural qui permet de moduler l'intensité de la lumière pour créer un éclairage idéal. Disponible en deux tailles, medium (Ø 60 cm) et large (Ø 80 cm), Elara s'adapte à une vaste gamme d'environnements, par exemple suspendue au-dessus d'une table dans une habitation, ou comme élément d'un agencement plus important tel qu'un hall d'hôtel ou un restaurant. ● FR

Der Name Elara erinnert an die Astronomie und die griechische Mythologie, und so ahmt das geometrische Design der Leuchte die Flugbahn der Planeten im Universum nach. Inspiriert von diesen astralen Bewegungen besteht die Leuchte aus zwei Metallringen, von denen einer in verschiedenen Winkeln positioniert werden kann, um eine fließende Bewegung zu erzeugen, sowie aus einer kleinen Kugel am unteren Ende der Leuchte, welche die Lichtquelle enthält. Der zentrale, horizontale Ring kann in verschiedenen Höhen und Winkeln positioniert werden, so dass die Benutzenden mit der Projektion von Licht und Schatten experimentieren können. Darüber hinaus ist Elara über einen an der Wand angebrachten Dimmer stufenlos regelbar, so dass die Lichtintensität je nach Bedarf angepasst werden kann, um individuellen Beleuchtungskonzepten gerecht zu werden. Erhältlich in zwei Größen, Medium (Ø 60 cm) und Large (Ø 80 cm), eignet sich Elara für eine Vielzahl von Umgebungen, wie z. B. über einem Esstisch im Wohnbereich oder als Teil einer größeren Installation in öffentlichen Räumen, wie einer Hotel-Lounge oder einem Restaurant. ● DE

Elara medium ↘ Suspension lamp **NEW LAMP**



Elara large ↘ Suspension lamp **NEW LAMP**

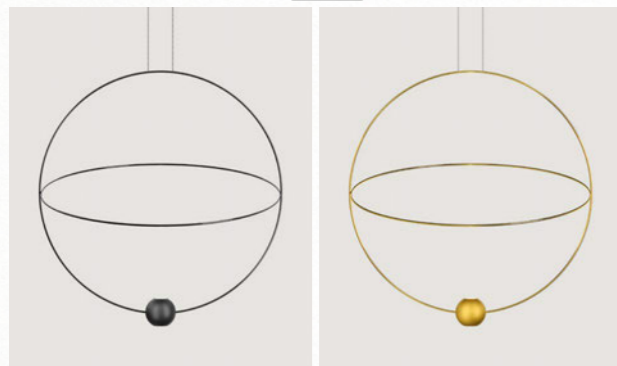

El nombre Elara evoca la astronomía y la mitología griega y su diseño geométrico imita la trayectoria de los planetas en el universo. Inspirada en el movimiento astral, la lámpara se caracteriza por dos anillos metálicos, uno de los cuales se puede colocar en distintos ángulos para crear fluidez y movimiento, y una pequeña esfera en el extremo inferior de la lámpara que contiene la fuente luminosa. El anillo central se puede colocar de forma que alcance distintas alturas y ángulos y permite a los usuarios experimentar la proyección de luces y sombras. Además Elara puede ajustarse con un regulador que controla el interruptor de pared y permite modular la intensidad de la luz para crear un esquema de iluminación ideal propio. Disponible en dos tamaños, medium (mediano) (Ø 60 cm) y large (grande) (Ø 80 cm), Elara se adapta a una amplia gama de ambientes, como por ejemplo encima de una mesa de comedor en un entorno residencial, o como parte de una instalación más grande en espacios públicos como el salón de un hotel o un restaurante. ● ES

Название Elara напоминает нам об астрономии и греческой мифологии, ее геометрический дизайн имитирует траектории движения планет во вселенной. Лампа, вдохновленная движением звезд, имеет два металлических кольца, одно из которых может устанавливаться под разными углами, создавая текучесть и мобильность, и небольшую сферу на нижней стороне лампы, содержащей внутри источник освещения. Центральное кольцо можно располагать на различной высоте и под разными углами, что позволяет пользователям экспериментировать с проекцией света и тени. Дополнительно к этому, Elara может регулироваться с помощью диммера, управляемого настенным выключателем, позволяющего регулировать интенсивность света и создавать собственную идеальную схему освещения. Elara выпускается в двух размерах, средний (Ø 60 см) и большой (Ø 80 см), и адаптируется к самым разнообразным помещениям, она может быть подвешена над

обеденным столом в жилом помещении или может стать частью более крупной инсталляции в общественных пространствах, таких как холл отеля или ресторан. ● RU

Elara一名呼应天文学和希腊神话,同时它的几何设计还仿照宇宙中的行星运行轨迹。受星体运动的启发,两只金属圆环是这款灯的特色所在,其中一只能够以不同角度定位,从而产生流动性和运动性,并使灯体下端形成一个容纳光源的小球体。中心圆环通过定位可达到不同高度和角度,允许用户尝试光与影的投射。此外,Elara可通过由壁式开关控制的调光器进行调光,使您能够在调整光线强度后营造理想的照明解决方案。Elara提供medium中号(Ø 60厘米)和large大号(Ø 80厘米)两种尺寸,适用于各种环境,例如居家环境中的餐桌上方或是在酒店休息室和餐厅等公共空间中作为大型装置的组成部分。● ZH

## Elara, design by Nika Zupanc, 2022

### Suspension lamp

#### Elara medium

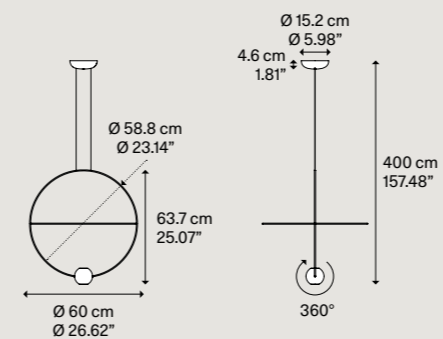

Net weight/Peso netto: 1.9 kg

Pack/Colli: 1

#### Light source Sorgente luminosa

LED  
≈ 3000 K  
≈ 27 W  
Side I 2260 lm  
Side II 845 lm  
≈ 1000 mA  
≈ CRI 90  
≈ MacAdam 3-Step

LED and driver included  
LED e driver inclusi

#### Metal structure Montatura in metallo

● Glossy Black  
Nero Lucido  
● Glossy Gold  
Oro Lucido

#### Metal sphere Sfera in metallo

● Extra Matte Black  
Nero Extra Opaco  
● Matte Gold  
Oro Opaco

#### Code Codice

20621 2230U

20621 5030U

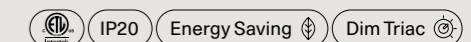

#### Elara large

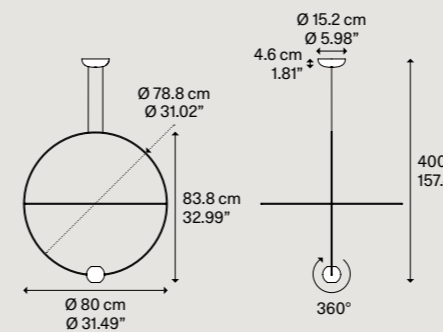

Net weight/Peso netto: 2 kg

Pack/Colli: 1

#### Light source Sorgente luminosa

LED  
≈ 3000 K  
≈ 27 W  
Side I 2260 lm  
Side II 845 lm  
≈ 1000 mA  
≈ CRI 90  
≈ MacAdam 3-Step

LED and driver included  
LED e driver inclusi

#### Metal structure Montatura in metallo

● Glossy Black  
Nero Lucido  
● Glossy Gold  
Oro Lucido

#### Metal sphere Sfera in metallo

● Extra Matte Black  
Nero Extra Opaco  
● Matte Gold  
Oro Opaco

#### Code Codice

20622 2230U

20622 5030U

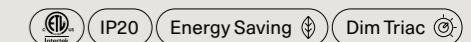

#### Adjustable light Luce orientabile

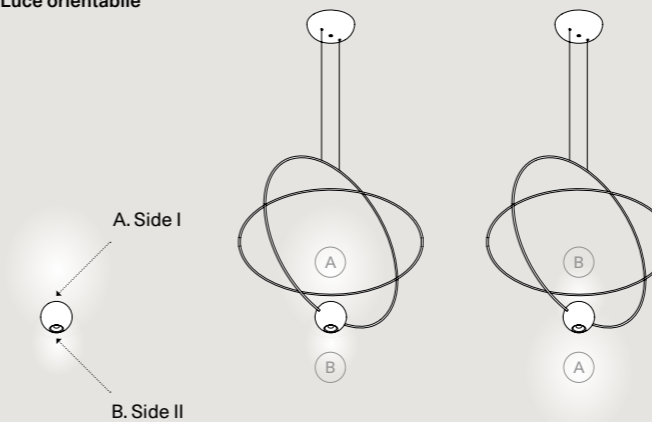

#### Adjustable ring Anello orientabile

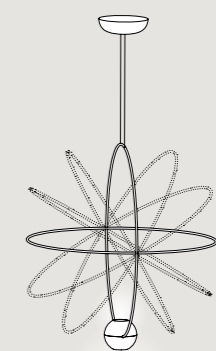

# New Concept: Hover

Part 1 - New Concept: Hover

Floor lamp



○ Matte White

Table lamp



○ Matte White

## Hover

The Hover table and floor lamps feature a lamp shade that looks as if it is detached from the base, connected seamlessly by a single cable that runs through the stem and comes out of the other end. The end result creates an illusion that the light source is almost weightless and floating in the air, like a balloon. Hover features a dimmer controlled by a power switch on the upper end of the stem; users can simply touch the top of the stem to modulate the intensity of the light. All typically external technical functions have been carefully incorporated within the lamp's internal structure. Additionally, the power supply comes in the form of a USB cable.

Available as a table or floor lamp, Hover suits different uses such as on a desk, side table or next to a sofa. The floor lamp could also be used for public spaces including an airport lounge, a hotel room or lobby.

Le lampade da tavolo e da terra Hover presentano un paralume che sembra separato dalla base, collegato perfettamente da un unico cavo che attraversa lo stelo per poi uscirne. Il risultato finale crea l'illusione che la sorgente luminosa sia quasi priva di peso e fluttui nell'aria, come un palloncino.

Hover è dotata di un dimmer controllato da un interruttore di alimentazione posto all'estremità superiore dello stelo; gli utenti possono semplicemente toccare la parte superiore dello stelo per modulare l'intensità della luce. Tutte le funzioni tecniche tipicamente esterne sono state accuratamente incorporate nella struttura interna della lampada. Inoltre, l'alimentazione è fornita grazie ad un cavo USB.

Disponibile come lampada da tavolo o da terra, Hover si adatta a diversi usi, come ad esempio su una scrivania, un tavolino o accanto ad un divano. La versione da terra può essere utilizzata anche in spazi pubblici come in una lounge di un aeroporto, in una camera di un hotel o una hall.

Floor lamp, Table lamp

Hover table and floor,  
FINISH Matte White

Hover, *design by YOY Studio, 2022*





Hover table and floor, FINISH Matte White



Hover, USB socket

Hover table, FINISH Matte White





1



2

1–Hover, the lamp shade is connected seamlessly by a single cable that runs through the stem and comes out of the other end

2–Hover, switch on and off and dim the light intensity

Hover floor, FINISH Matte White





Hover table,  
FINISH Matte White



1

1-Hover, the shade comprises a  
sheet made from a special compound  
of paper and polymer film



Hover table, FINISH Matte White

Hover floor and table,  
FINISH Matte White



L'abat-jour des lampes de table et des lampadaires Hover semble séparé de la base et parfaitement relié par un câble unique qui traverse entièrement la tige. Le résultat final crée l'illusion d'une source lumineuse qui flotte dans l'air quasiment en apesanteur, comme un ballon. Hover est équipé d'un gradateur commandé par un interrupteur d'alimentation situé à l'extrémité supérieure de la tige ; les utilisateurs n'ont qu'à toucher le haut de la tige pour moduler l'intensité de la lumière. Toutes les fonctions techniques habituellement externes ont été soigneusement intégrées dans la structure interne de la lampe. En outre, l'alimentation est fournie via un câble USB. Disponible en lampe de table ou en lampadaire, Hover convient à différents usages, comme lampe de bureau, de table basse ou à côté d'un canapé. La version au sol peut également être installée dans des espaces publics tels qu'un lounge d'aéroport, une chambre d'hôtel ou un hall. ● FR

Die Tisch- und Stehleuchten Hover verfügen über einen Leuchtschirm, der vom Sockel getrennt zu sein scheint, verbunden auf perfekte Weise durch ein einziges Kabel, das durch den Schaft hindurch und aus ihm herausführt. Das Endergebnis erzeugt die Illusion, dass die Lichtquelle fast schwerelos ist und wie ein Ballon in der Luft schwebt. Hover ist mit einem Dimmer ausgestattet, der über einen Schalter am oberen Ende des Schaftes reguliert wird; die Benutzer können die Lichtintensität durch einfaches Berühren des oberen Endes des Schaftes einstellen. Alle typischen externen technischen Funktionen wurden sorgfältig in die innere Struktur der Leuchte integriert. Außerdem erfolgt die Stromversorgung über ein USB-Kabel. Erhältlich als Tisch- oder Stehleuchte, eignet sich Hover für verschiedene Verwendungszwecke, z. B. auf einem Schreibtisch, einem Beistelltisch oder neben einem Sofa. Die Bodenversion kann auch in öffentlichen Räumen wie einer Flughafenlounge, einem Hotelzimmer oder einer Empfangshalle eingesetzt werden. ● DE

Las lámparas de sobremesa y de pie Hover poseen una pantalla que parece separada de la base, conectada perfectamente por un solo cable que atraviesa la barra y luego sale. El resultado final da la sensación de que la fuente luminosa prácticamente no pesa y flota en el aire, como un globo. Hover está equipada con un regulador que controla un interruptor de alimentación situado en el extremo superior de la barra; los usuarios, simplemente tocando la parte superior de la barra, pueden regular la intensidad de la luz. Todas las funciones técnicas que normalmente están fuera se han incorporado minuciosamente en la estructura interna de la lámpara. Además, la alimentación se suministra gracias a un cable USB. Hover, disponible como lámpara de sobremesa o de pie, se adapta a distintos usos, como por ejemplo en un escritorio, una mesita o junto a un sofá. La versión de pie también se puede utilizar en espacios públicos como en la sala de un aeropuerto, una habitación de hotel o un vestíbulo. ● ES

Настольные лампы и торшеры Hover имеют абажур, который кажется отделенным от основания и соединенным одним кабелем, пересекающим стержень, а затем выходящим наружу. В результате возникает иллюзия невесомости источника света, парящего в воздухе, как воздушный шар. Hover оснащен диммером, управляемым выключателем, расположенным на верхнем конце стержня; пользователи могут отрегулировать интенсивность света, просто прикоснувшись к верхней части стержня. Все технические функции, обычно находящиеся снаружи, были встроены во внутреннюю структуру светильника. Питание также подается по кабелю USB. Hover выпускается в виде настольной лампы или торшера, и подходит для различного применения, на письменном столе, журнальном столике или рядом с диваном. Напольный вариант может также устанавливаться в общественных зданиях, например в зале аэропорта, в гостиничном номере или в холле. ● RU

Hover的台灯款和落地灯款均带有一个看似与底座分开的灯罩，但灯罩与底座之间却由一根从灯罩部位穿插而过的单根线缆完美连接。最终结果营造一种幻觉，光源仿佛几乎没有重量且会像气球一般漂浮于空中。Hover配有一部由位于灯罩上端的电源开关控制的调光器；用户只需轻触灯罩顶部便可调节光的强度。所有典型的外部技术功能均已巧妙整合至灯件的内部结构之中。此外，电源供给是通过一根USB线缆完成的。Hover提供台灯或落地灯两个版本，适用于不同用途，例如放在书桌、咖啡桌上或沙发近旁。落地灯版本也可用于机场休息室、酒店房间或大堂等公共场所。● ZH

Hover ▾ Floor lamp, Table lamp **NEW LAMP**



## Hover, design by YOY Studio, 2022

Floor lamp

### Hover

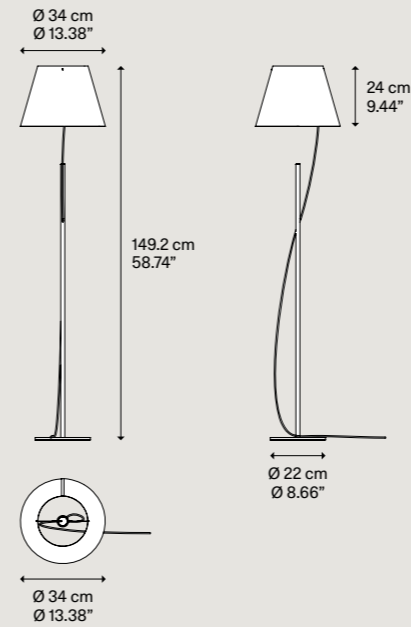

Net weight/ Peso netto: 6 kg

Pack/ Colli: 1

**Light source**  
Sorgente luminosa

LED  
 ▾ 2700 K  
 ▾ 6 W/ 1000 lm  
 ▾ 5V 2A  
 ▾ CRI 90  
 ▾ MacAdam 3-Step

LED and driver included  
LED e driver inclusi

**Metal structure**  
Montatura in metallo

● Matte White  
Bianco Opaco

**Paper diffuser**  
Diffusore in carta

● Matte White  
Bianco Opaco

**Code**  
Codice

18471 1027

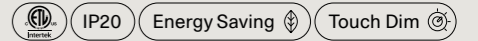
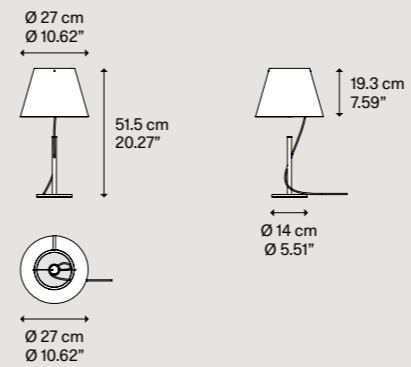

Table lamp

### Hover



Net weight/ Peso netto: 2.2 kg

Pack/ Colli: 1

**Light source**  
Sorgente luminosa

LED  
 ▾ 2700 K  
 ▾ 6 W/ 1000 lm  
 ▾ 5V 2A  
 ▾ CRI 90  
 ▾ MacAdam 3-Step

LED and driver included  
LED e driver inclusi

**Metal structure**  
Montatura in metallo

● Matte White  
Bianco Opaco

**Paper diffuser**  
Diffusore in carta

● Matte White  
Bianco Opaco

**Code**  
Codice

18480 1027

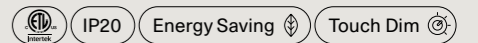

Touch dimmer



# Finishes

New Finish: *Glossy Bronze*

● Glossy Bronze/Bronzo Lucido

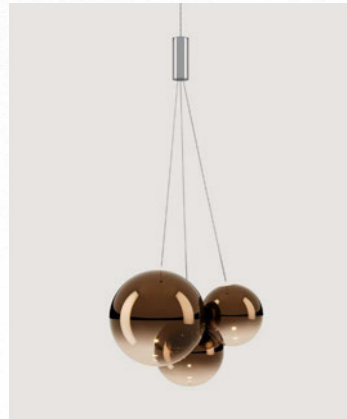

Random

● Glossy Bronze/Bronzo Lucido

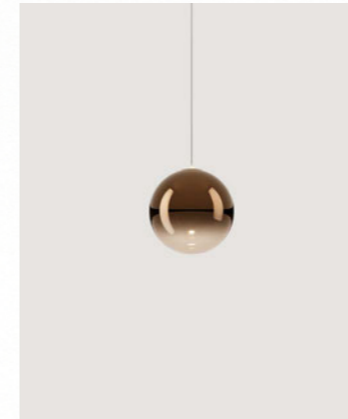

Random Solo 12

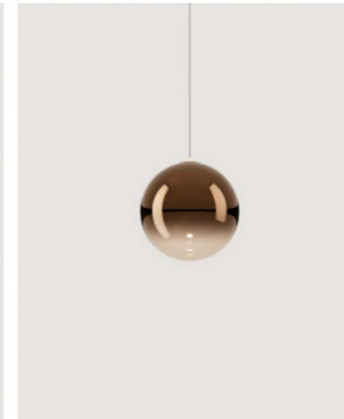

Random Solo 14

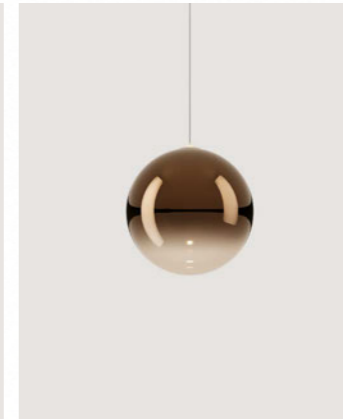

Random Solo 18

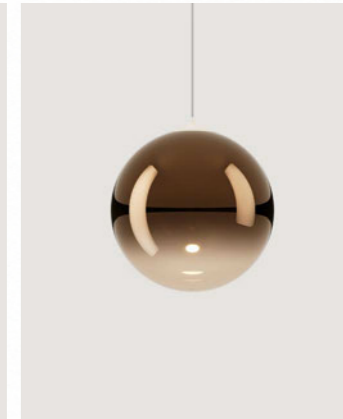

Random Solo 23

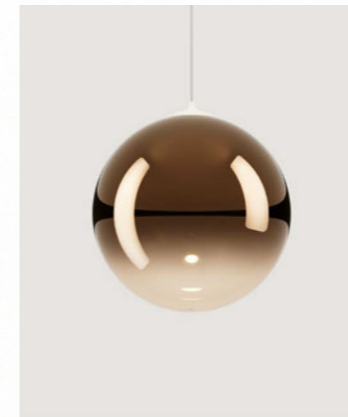

Random Solo 28

## New Finish: GLOSSY BRONZE

As brilliant as the creative touch it bestows on the environment, *Glossy Bronze* is synonymous with alluring beauty. *Random* and *Random Solo* are now available in this warm and earthy colour that inspires stability and sturdiness and infuses calmness to any living environments. Its materic nature warms the ambience with a few simple touches and creates a distinctly homely atmosphere.

Brillante come il tocco creativo che infonde all'ambiente, *Glossy Bronze* è sinonimo di bellezza affascinante. *Random* e *Random Solo* sono ora disponibili in questa finitura calda e terrosa, che ispira stabilità e robustezza e infonde calma a qualsiasi ambiente abitativo. La sua matericità scalda l'ambiente con pochi semplici tocchi e crea un'atmosfera decisamente confortevole.

### Random

↳ Cluster suspension lamp  
p. 41

- Clear
- Frosted White
- Chrome
- Glossy Smoke
- Glossy Bronze NEW
- Gold
- Rose Gold

### Random Solo

↳ Cluster suspension lamp  
p. 47

- Clear
- Frosted White
- Chrome
- Glossy Smoke
- Glossy Bronze NEW
- Gold
- Rose Gold

Random, design by Chia-Ying Lee, 2017

Spec sheet p. 54



Random, FINISHES Glossy  
Smoke and Glossy Bronze



Random, composition of 7 lights on a *rectangular canopy*, FINISHES Glossy Bronze and Chrome

Random, *recessed micro canopy*, FINISHES Glossy Bronze and Chrome



New Glossy Finish



Random, FINISH Glossy Bronze

Random, *recessed micro canopy*,  
FINISHES Glossy Bronze and Clear



Aussi brillant que la touche créative qu'il diffuse dans l'environnement, *Glossy Bronze* est une source de beauté irrésistible. *Random* et *Random Solo* sont désormais disponibles dans cette finition chatoyante et terreuse qui évoque stabilité, force et tranquillité dans tous les styles d'habitation. Quelques touches de ce caractère matérielle suffisent pour octroyer à l'espace une chaleur et une atmosphère résolument confortables. ● FR

So brillant wie der kreative Touch, den es dem Raum verleiht, ist *Glossy Bronze* ein Synonym für faszinierende Schönheit. *Random* und *Random Solo* sind jetzt in dieser warmen, erdigen Ausführung erhältlich, die Stabilität und Robustheit ausstrahlt und in jeder Wohnumgebung eine gewisse Ruhe verbreitet. Seine Materialität wärmt das Ambiente mit wenigen einfachen Berührungen und schafft eine ausgesprochen wohnliche Atmosphäre. ● DE

Brillante como el toque creativo que infunde al ambiente, *Glossy Bronze* es sinónimo de belleza deslumbrante. Ahora *Random* y *Random Solo* están disponibles en este acabado cálido y terroso que inspira estabilidad y solidez e infunde calma a cualquier ambiente residencial. Su materialidad da calidez al ambiente con tan solo unos simples toques y crea sin duda una atmósfera confortable. ● ES

Блестящий, как и творческий штрих, передающийся всему помещению, *Glossy Bronze* является синонимом чарующей красоты. Теперь *Random* и *Random Solo* выпускаются с теплой и естественной отделкой, внушающей ощущение стабильности и надежности и приносящей спокойствие в любое жилище. Ее материалность согревает помещение своим прикосновением и создает осязаемую атмосферу уюта. ● RU

光彩照人，就如一丝倾入环境的创意润饰，亮光铜色是迷人之美的代名词。*Random*和*Random Solo*现下提供这款温暖而朴实的饰面，激发稳定性和坚固性并为任何居住环境注入平和安宁。它的实质性，通过一些简约润饰为环境升温并营造出一片绝对舒适的氛围。● ZH

## Random Solo, design by Chia-Ying Lee, 2020



Random Solo, FINISHES Glossy Bronze and Clear



Random Solo, composition of 9 lights on a *round canopy*, FINISHES Glossy Bronze, Glossy Smoke and Clear

Random Solo, *recessed micro canopy*, FINISHES Glossy Bronze, Glossy Smoke and Clear



Random Solo, composition of 14 lights on a round canopy, FINISHES Glossy Bronze and Clear

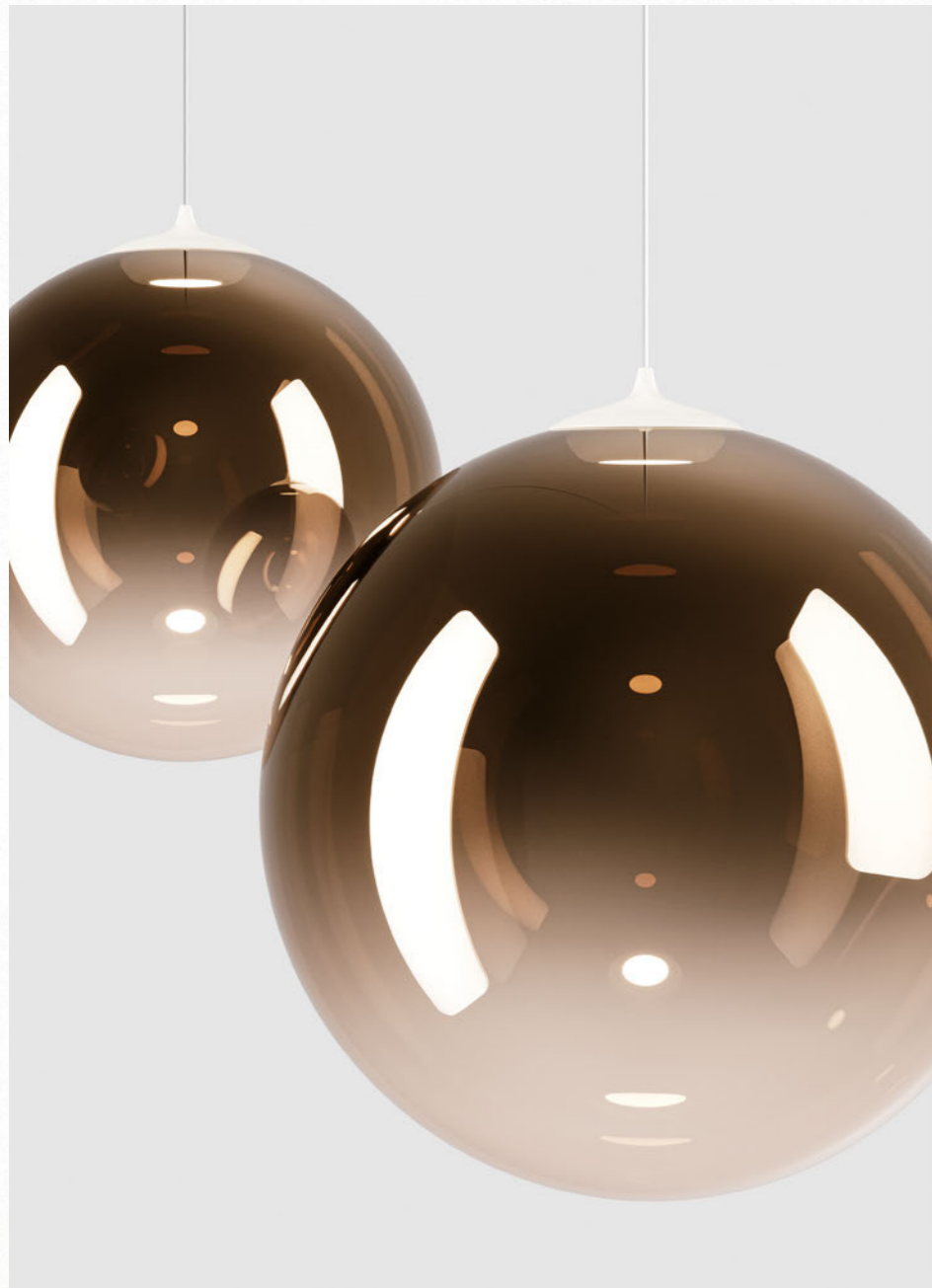

Random Solo, FINISH Glossy Bronze

Spec sheet

Random 54  
*design by Chia-Ying Lee*  
Cluster suspension lamp

Random Solo 55  
*design by Chia-Ying Lee*  
Cluster suspension lamp

# Random, design by Chia-Ying Lee, 2017

Cluster suspension lamp

## Random

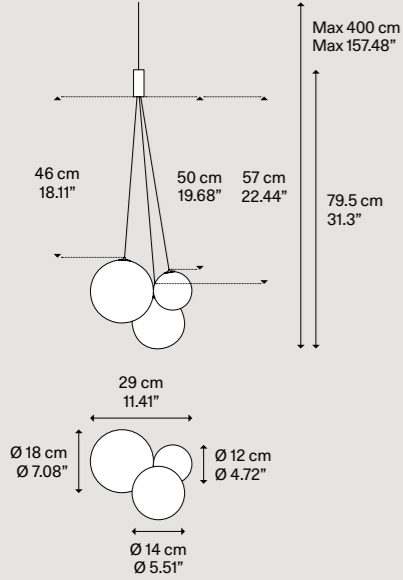

Light source  
Sorgente luminosa

LED  
 ↘ 2700 K  
 ↘ 3 × 1 W/450 lm  
 ↘ 350 mA  
 ↘ CRI 90  
 ↘ MacAdam 3-Step

LED and driver included  
LED e driver inclusi

Metal structure  
Montatura in metallo

Chrome  
Cromo

Blown glass diffuser  
Diffusore in vetro soffiato

	Clear Trasparente	16420 0027U
	Frosted White Bianco Satinato	16420 1327U
	Chrome Cromo	16420 4027U
	Glossy Smoke Fumo Lucido	16420 4327U
	Glossy Bronze <sup>NEW</sup> Bronzo Lucido	16420 4627U
	Gold Oro	16420 5027U
	Rose Gold Oro Rosa	16420 5527U

Code  
Codice

Net weight/Peso netto: 1.0 kg

Pack/Colli: 2

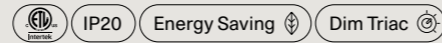

# Random Solo, design by Chia-Ying Lee, 2020

Cluster suspension lamp

## Random Solo 12

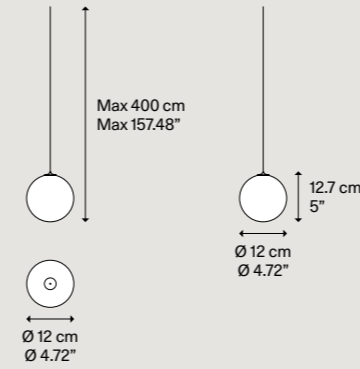

Light source  
Sorgente luminosa

LED  
 ↘ 2700 K  
 ↘ 1 W/150 lm  
 ↘ 350 mA  
 ↘ CRI 90  
 ↘ MacAdam 3-Step

LED and driver included  
LED e driver inclusi

Blown glass diffuser  
Diffusore in vetro soffiato

	Clear Trasparente	17111 0027U
	Frosted White Bianco Satinato	17111 1327U
	Chrome Cromo	17111 4027U
	Glossy Smoke Fumo Lucido	17111 4327U
	Glossy Bronze <sup>NEW</sup> Bronzo Lucido	17111 4627U
	Gold Oro	17111 5027U
	Rose Gold Oro Rosa	17111 5527U

Code  
Codice

Net weight/Peso netto: 0.25 kg

Pack/Colli: 2

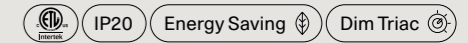

Suspension lamps must be installed on a canopy.

Le lampade a sospensione devono essere installate su rosone.



Suspension lamps must be installed on a canopy. Not suitable for the Radial System.

Le lampade a sospensione devono essere installate su rosone. Non utilizzabile sul Sistema Radiale.

# Random Solo, design by Chia-Ying Lee, 2020

Cluster suspension lamp

## Random Solo 14

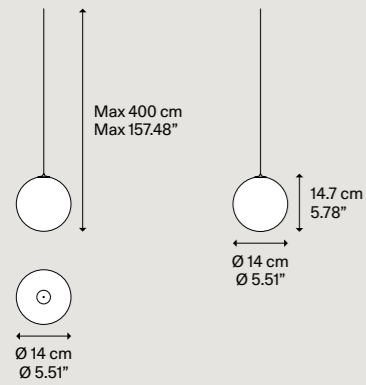

Light source  
Sorgente luminosa

LED  
 ↘ 2700 K  
 ↘ 1 W/150 lm  
 ↘ 350 mA  
 ↘ CRI 90  
 ↘ MacAdam 3-Step

LED and driver included  
LED e driver inclusi

Blown glass diffuser  
Diffusore in vetro soffiato

	Clear Trasparente	17112 0027U
	Frosted White Bianco Satinato	17112 1327U
	Chrome Cromo	17112 4027U
	Glossy Smoke Fumo Lucido	17112 4327U
	Glossy Bronze <sup>NEW</sup> Bronzo Lucido	17112 4627U
	Gold Oro	17112 5027U
	Rose Gold Oro Rosa	17112 5527U

Net weight/Peso netto: 0.32 kg

Pack/Colli: 2

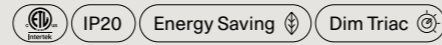

# Random Solo, design by Chia-Ying Lee, 2020

Cluster suspension lamp

## Random Solo 18

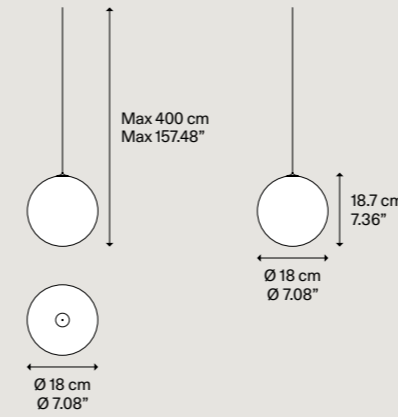

Light source  
Sorgente luminosa

LED  
 ↘ 2700 K  
 ↘ 1 W/150 lm  
 ↘ 350 mA  
 ↘ CRI 90  
 ↘ MacAdam 3-Step

LED and driver included  
LED e driver inclusi

Blown glass diffuser  
Diffusore in vetro soffiato

	Clear Trasparente	17113 0027U
	Frosted White Bianco Satinato	17113 1327U
	Chrome Cromo	17113 4027U
	Glossy Smoke Fumo Lucido	17113 4327U
	Glossy Bronze <sup>NEW</sup> Bronzo Lucido	17113 4627U
	Gold Oro	17113 5027U
	Rose Gold Oro Rosa	17113 5527U

Net weight/Peso netto: 0.8 kg

Pack/Colli: 2

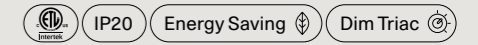

Suspension lamps must be installed on a canopy. Not suitable for the Radial System.

Le lampade a sospensione devono essere installate su rosone. Non utilizzabile sul Sistema Radiale.



Suspension lamps must be installed on a canopy. Not suitable for the Radial System.

Le lampade a sospensione devono essere installate su rosone. Non utilizzabile sul Sistema Radiale.

# Random Solo, design by Chia-Ying Lee, 2020

Cluster suspension lamp

## Random Solo 23

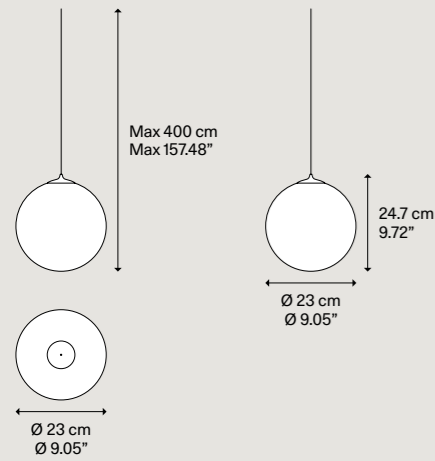

Light source  
Sorgente luminosa

LED  
 ↘ 2700 K  
 ↘ 3 W/450 lm  
 ↘ 350 mA  
 ↘ CRI 90  
 ↘ MacAdam 3-Step

LED and driver included  
LED e driver inclusi

Blown glass diffuser  
Diffusore in vetro soffiato

Color	Code
Clear Trasparente	17114 0027U
Frosted White Bianco Satinato	17114 1327U
Chrome Cromo	17114 4027U
Glossy Smoke Fumo Lucido	17114 4327U
Glossy Bronze <sup>NEW</sup> Bronzo Lucido	17114 4627U
Gold Oro	17114 5027U
Rose Gold Oro Rosa	17114 5527U

Net weight/Peso netto: 1.1 kg

Pack/Colli: 2

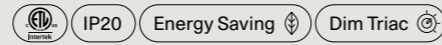

Suspension lamps must be installed on a canopy. Not suitable for the Radial System.

Le lampade a sospensione devono essere installate su rosone. Non utilizzabile sul Sistema Radiale.

# Random Solo, design by Chia-Ying Lee, 2020

Cluster suspension lamp

## Random Solo 28

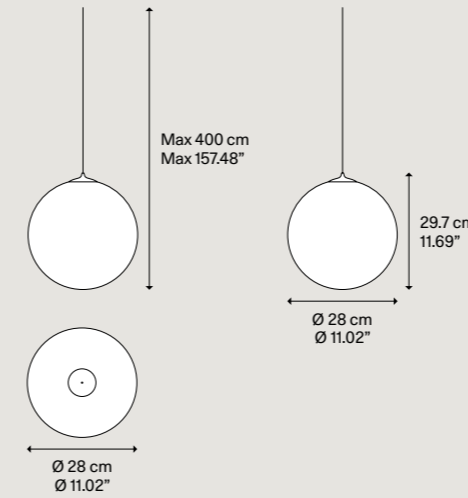

Light source  
Sorgente luminosa

LED  
 ↘ 2700 K  
 ↘ 3 W/450 lm  
 ↘ 350 mA  
 ↘ CRI 90  
 ↘ MacAdam 3-Step

LED and driver included  
LED e driver inclusi

Blown glass diffuser  
Diffusore in vetro soffiato

Color	Code
Clear Trasparente	17115 0027U
Frosted White Bianco Satinato	17115 1327U
Chrome Cromo	17115 4027U
Glossy Smoke Fumo Lucido	17115 4327U
Glossy Bronze <sup>NEW</sup> Bronzo Lucido	17115 4627U
Gold Oro	17115 5027U
Rose Gold Oro Rosa	17115 5527U

Net weight/Peso netto: 1.8 kg

Pack/Colli: 2

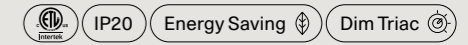

Suspension lamps must be installed on a canopy. Not suitable for the Radial System.

Le lampade a sospensione devono essere installate su rosone. Non utilizzabile sul Sistema Radiale.

# Lodes Product Configurator

Create truly unique combinations of light fixtures with *Lodes* canopies! Select a *lamp*, choose your *canopy* and create your customised *composition*.

Crea combinazioni di luci veramente uniche con i *rosoni* Lodes! Seleziona una *lampada*, scegli il tuo *rosone* e crea la tua *composizione* personalizzata.

## STEP 1 Select your *lamp*:

### Cluster suspension lamp

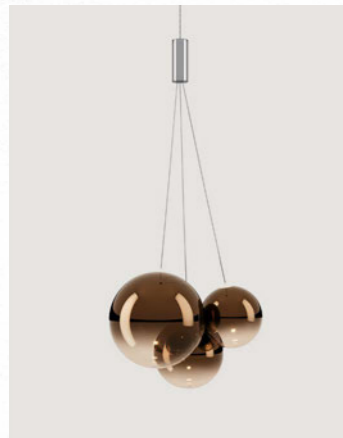

Random  
Glossy Bronze NEW

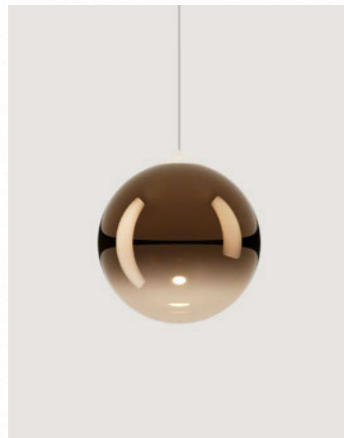

Random Solo  
Glossy Bronze NEW \*

## STEP 2 Choose your *canopy*:

### Single canopies



Standard

Mini

Recessed Micro

### Multiple canopies

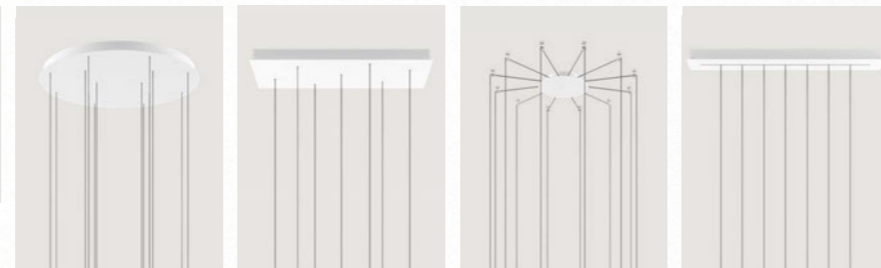

Round

Rectangular

Radial

Track

## STEP 3 Create your *composition*:

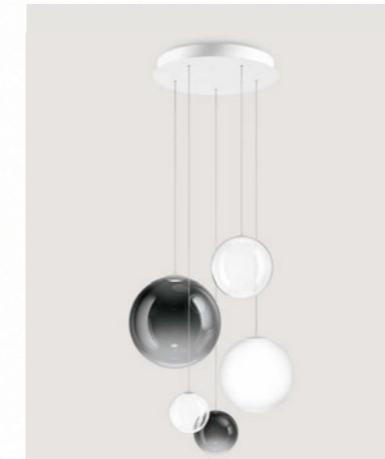

Random Solo, Round



Random, Track



Random, Recessed Micro

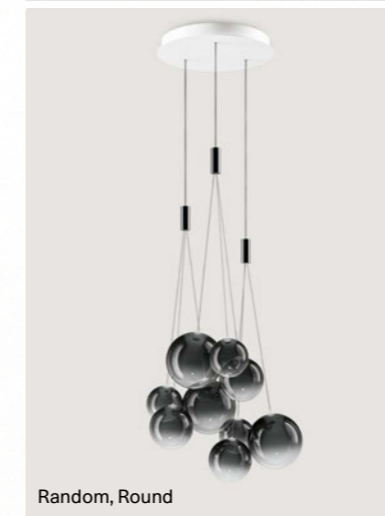

Random, Round

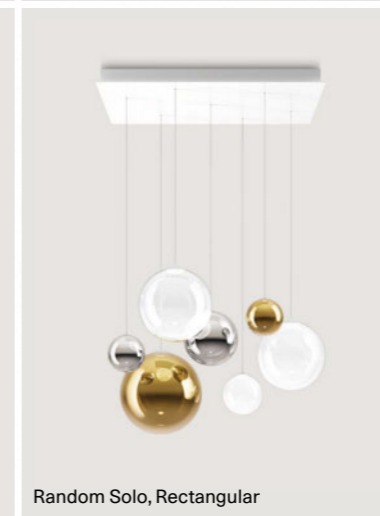

Random Solo, Rectangular

### Canopies

Canopies are systems which allow to conceal the electrical joints of a light source, creating functional solutions to support the body of wall or ceiling suspension lights. *Lodes's canopies* are also a stand-out decorative element which helps to give individual light fixtures an original look and to make combinations of light fixtures truly unique.

Choose a product and create your own composition with *Lodes canopies*.

### Rosoni

Sistemi che permettono di occultare i collegamenti elettrici di un punto luce, i *rosoni* sono soluzioni funzionali per sostenere i corpi luce a sospensione. I *rosoni Lodes* sono anche un elemento decorativo differenziante che contribuisce a rendere originali le singole lampade e uniche le loro combinazioni.

Scegli un prodotto e crea la tua composizione con i *rosoni Lodes*.

Discover more





**Art. 1 Recital**  
Unless otherwise provided for in a separate written agreement between the parties, every sale of products of Lodes S.r.l., VAT 02992370276 (hereinafter, "the Seller") is governed by the following General Conditions of Sale that must be considered as an essential part of this agreement and shall be deemed to have been accepted by the Buyer even though the latter has not signed them. Any clause unilaterally added by the Buyer in the documentation signed by it and / or in its correspondence, being against or in any case in addition to the general conditions or to those specific expressly approved in writing by the Seller, shall be deemed as not written and shall be of no effect.

**Art. 2 Completion of the sale, quantities and prices**  
The sale is deemed to be completed once the Seller gives the written order confirmation also by fax and / or email or when deliveries are commenced in cases where the immediate delivery of the supply is requested, also in consideration of changes occurred and then accepted by the customer. The prices agreed are understood for products delivered ex works of the Seller and do not include services and accessory charges (such as VAT, special packaging, transport and installation costs, and/or assemblages and so on).

**Art. 3 Delivery, risk transfer and transport**  
Products are delivered to the Buyer at the Seller's plant or at another place indicated in writing by the Seller, and the risk transfer takes place with the delivery of the goods to the first carrier or Buyer in the events of collection of goods directly carried out by the latter. The products always travel at the Buyer's sole risk also when the carrier is selected and appointed by the Seller, being the latter freed from all responsibilities after having delivered the products to the carrier, this delivery is deemed to all effects being carried out directly by the said Buyer. The delivery terms agreed are to be understood as indicative. If the Seller is responsible for delay of delivery for a period of up to 60 days, the Buyer is not entitled either to refuse the supply or to request the termination of the agreement and / or the compensation for any damages. If the delay in delivery exceeds 60 days, the Buyer is entitled to request - by registered letter - the cancellation of the order and the reimbursement of the advances if paid. In any event, the Seller shall not be liable for and/or direct and indirect damages of any nature and for any reason due to the delay or the failure to carry out the supply.

**Art. 4 Reservation of title**  
The Buyer acquires property rights over the goods with the full payment of the price invoiced of the supplies but it takes the risks thereof as of the delivery.

**Art. 5 Products/features and conditions of use**  
Unless otherwise expressly agreed in writing by the parties, the conditions for using of the products are those communicated or in any case resulting from the drawings and technical specifications of the Seller, if any, or as described in the website [www.lodes.com/en/](http://www.lodes.com/en/) in relation to products. The quality levels of products are the standard quality levels of the Sellers, indicated in the relevant specifications as described on the Seller's website. It is always the Buyer's responsibility to identify and notify the Seller of the conditions of use of products before technically defining them. Failing any particular instructions from the Buyer, the Seller considers as usual conditions of use those it considered or described in its designs and technical documentation.

**Art. 6 Warranties**  
The products delivered are covered by a warranty for defects in material and manufacture for a period of 24 months as of the delivery if the Buyer is a natural person, otherwise the warranty period will be of 12 months as of the delivery. The Seller shall replace

the products delivered in this warranty period being faulty due to factory defects or in alternative, at its discretion, pay the Buyer an amount equal to the price already invoiced of the said products, being expressly excluded and waived any other right or claim by the Buyer also as compensation for direct and/or indirect damages or cost repayment borne by it (such as recovery, technical assistance, recalling costs, etc.). The Seller will anticipate the delivery of the replaced product, invoicing it regularly. Successively, when the product arrive to the Seller's warehouse, the latter will credit the amount of the defective product. The transport's costs will be paid by the Seller. Should the defected item be returned in an inadequate non-original packaging, with damages connected to the transport, The Seller will not credit any amount to the Buyer, and it will return the product to the sender at his own expenses. If the replacement was made for alleged defects in material and manufacture, but after the control carried out by the Seller, it is considered

(i) unfounded, due to the absence of defects; (ii) further damaged by insufficient packaging in the return transport (iii) spoiled by tampering made by the Buyer, all transportation costs and the entire value of the product will be charged to the latter. Any defectiveness or non-compliance of products shall be reported by the Buyer by writing to the Seller - in order to be valid - within 8 days from receipt of goods; any hidden defects shall be reported by the Buyer by writing to the Seller - always in order to be valid - within 8 days as of the relevant discovery. It being understood that the Seller will not be responsible for any defect even though hidden, being notified in writing, after 24 months of the delivery of goods. The warranty does not apply where the defects identified are due to the Buyer's negligence and / or to the use of products being not compliant with the information and explanations in any case gave by the Seller, technical provisions, to incorrect design, application, assembly or manufacture of the facilities in which they are installed, to incorrect maintenance carried out by unauthorized personnel, to improper cleaning since it is made with materials and manners being not suitable, to incorrect storage, handling and transport, to improper or imprudent use, also in the event of electrical system and its capacity being not suitable, or to circumstances that in any case cannot be related to the production defectiveness by the Seller. Every single product of the Seller corresponds to the mark laid down by the European Community with Directive 93 / 68 (extension of Directive 73 / 23) to confirm, with a mark recognized all over Europe, that the lights have undergone the electrical safety test required by European standards EN-60598-1-2 II ed. + CEI EN 60598-1 IV ed. corresponding to Italian standards CEI 34-21 + CEI 34-23, electrical safety standards referred to by all institutions, including the IMQ. The products indicated with the logo UL and/or ETL corresponds to the standards UL 1598 / CAN / USA C22.2 No.250.0 o UL 153.

**Art. 7 Buyer's Obligations**  
The Buyer is required to immediately take delivery of the goods given by the Seller to the carrier, or - where otherwise agreed - to timely collect them at the Seller's plant on the date on which the Seller communicates, by any means, that the goods are ready. Where the Buyer delays the collection of the production for a period exceeding 10 days, in addition to the payment of price it shall pay the Seller a proper compensation equal to 2% per day of the price invoiced for storing such products. The Buyer shall carry out the payments normally, in accordance with the terms and conditions specified in the invoice. For late payments it will be accrued by default without need of further notification interest under Legislative Decree no. 231 / 2002. In the event of payment delays, the Seller is entitled to immediately suspend any supply, even though it has concluded other agreements with the same Buyer. The failure to pay within the terms agreed will cause in any event the loss of favourable terms for the Buyer.

**Art. 8 Replacement of the Product**  
If a product is returned for commercial reasons or for a mistake in the order made by the Buyer, the Seller will retain an amount equal to the 20% of the total price as cost for reconditioning the product. If the returned product had already been used and / or it has been returned in an inadequate original packaging, with consequent transport damages, the Seller will not credit to the Buyer any amount and it will return the product to the sender at his own expenses. Only the articles in the catalogue and in the price list in force at the time of the request will be taken into consideration. Transport's costs are always charged to the Buyer. The repair of damaged products will be authorized only if the damage has been caused by the Buyer. The Buyer, once accepted repair costs, will take care of returning the damaged product to the Seller's warehouse and it will pay the costs of transporting the repaired product.

**Art. 9 Force majeure**  
If the Seller is unable to comply with the agreement due to force majeure or beyond its control events, the deadlines set for the supply are automatically extended for a period in which these effects continue. Where the obstacle to comply with the agreement is longer than 6 months, both parties may request the termination of the agreement and, in such event, the Seller repay the Buyer the advances received, if any, releasing itself from any additional obligation on it.

**Art. 10 Agreement**  
In the event of execution of a specific agreement signed by the parties, the said agreement together with its Annexes provides for and summarizes the obligations validly undertaken by the parties and being binding for them. The fulfilment by the parties will be subject to effective evaluation of the actual performance of the contractual tasks and duties to be carried out in good faith, with honesty and fairness. These General Conditions of Sale shall apply to the agreement, unless otherwise provided in writing by the parties or expressly provided in the said agreement.

**Art. 11 Privacy Policy**  
The Seller will use the data received from the Buyer in accordance with the provisions of the article 13 of EU Regulation 2016 / 679 of 27 April 2016 (GDPR). For more information are available at the following

**Art. 12 Disputes**  
Any dispute which may arise concerning the signing, validity, interpretation, performance, amendment and termination of the agreement or of these General Conditions of Sale will be settled according to principles and rule set forth in Article 13 below.

**Art. 13 Jurisdiction and Applicable Law**  
The Court of Milan, Italy, shall be held exclusively competent, being any other court of competent jurisdiction expressly excluded, and the Italian Law shall be applicable.

**Art. 14 Website**  
These General Conditions of Sale are those indicated on the website [www.lodes.com/en/](http://www.lodes.com/en/) and may be printed and reproduced on paper. The Seller undertakes to update the website [www.lodes.com/en/](http://www.lodes.com/en/) by publishing on it the version of the General Conditions of Sale as amended from time to time.

**Limited Warranty**  
12 months  
for United States Only

**Coverage**  
Lodes S.r.l., with headquarter in 30020 Marcon (VE), Via Pialoi 32 Italy, VAT N.: 02992370276 (hereinafter, "WARRANTOR") warrants that each WARRANTOR PRODUCT will be free from defects in material and workmanship for a period of twelve months from the date of shipment / delivery of the PRODUCT (that can be identified by the "Studio Italia Design" or "Lodes" trademark, trade name, or logo affixed to them). The Limited Warranty is referred to herein as "the Limited Warranty." The PURCHASER's sole and exclusive remedy under this Limited Warranty for defects in the PRODUCT shall be the repair, replacement or refund of the purchase price, in WARRANTOR's sole discretion, of the defective PRODUCT, or components thereof.

**Not Covered**  
This Limited Warranty also does not apply to, and WARRANTOR shall have no liability or responsibility in respect of, damages or expenses relating to:

- The failure to properly store, transport, install or use the PRODUCT as, for example, specified in any manuals or other literature supplied by WARRANTOR, on WARRANTOR's website, or in accordance with any applicable laws, codes, regulators or standards;

- Any PRODUCT purchased from any entity other than WARRANTOR;

- Alteration, change or modification of the PRODUCT, including its subcomponents, parts or assemblies;

- WARRANTOR also makes no warranty that a PRODUCT manufactured does not infringe the intellectual property or other proprietary rights of any third party;

- Accidents, misuse, abuse, abnormal use, improper use, negligent use, wilful misconduct, or use exceeding the recommended and permitted limits of the PRODUCT, and / or normal wear or deterioration;

- Any defect or non-conformity that has not been timely and promptly communicated in writing to WARRANTOR as set forth herein.

- Any damage, cost or expense caused by Act of God; or

- Loss of time, loss of use, inconvenience, loss of profits, lost business, lost business opportunities, damage to reputation, goodwill and any incidental or consequential damages arising out of or relating to the PRODUCT, or other matters not specifically covered hereunder.

**Procedure**  
Upon delivery, PURCHASER shall, within one (3) business day, inspect the PRODUCT for conformity and visible defects. PURCHASER shall give WARRANTOR immediate written, specific and detailed notice of any non-conformities or defects regarding the PRODUCT. Upon receipt of the written notice of claim, WARRANTOR shall have the right to inspect the PRODUCT. In the event of a defect covered by this Limited Warranty, WARRANTOR will, at WARRANTOR's discretion, repair or replace the PRODUCT or any component of the PRODUCT or refund the purchase price for that particular PRODUCT. In the event that PURCHASER submits a warranty claim that, in the sole reasonable discretion of the WARRANTOR, is unfounded, the PURCHASER shall reimburse the WARRANTOR all reasonable costs incurred by the WARRANTOR

in evaluating the warranty claim (i.e. travel, lodging, expert evaluations, etc.). WARRANTOR must approve, in advance and in writing, all repairs or replacements covered under or performed pursuant to this Limited Warranty. Any warranty repairs or service must be performed exclusively by WARRANTOR or other authorized representative of WARRANTOR or by another servicing facility pre-approved in writing by WARRANTOR. Acceptance of any Limited Warranty claim is not an admission that any PRODUCT or any of its component parts are defective. The PURCHASER forfeits any rights it may have under this Limited Warranty if the PURCHASER does not follow the procedure described herein. All requests and notices under this Limited Warranty shall be directed to:

Lodes S.r.l.,  
Via Pialoi n. 32, 30020  
Marcon (VE), Italy  
E-mail: [legal@lodes.com](mailto:legal@lodes.com)  
Fax: +39 0414 56 73 37

**Limitation of Damages**  
LIMITATION OF DAMAGES. Except as expressly provided by this Limited Warranty, WARRANTOR SHALL NOT BE RESPONSIBLE FOR ANY INCIDENTAL OR CONSEQUENTIAL DAMAGES ASSOCIATED WITH THE USE OR NON-USE OF THE PRODUCT OR A CLAIM UNDER THIS LIMITED WARRANTY, WHETHER THE CLAIM IS BASED ON CONTRACT, TORT OR OTHERWISE. The foregoing statements of warranty are exclusive and in lieu of all other remedies or damages. Some States do not allow the exclusion or limitation of incidental or consequential damages, so only in this case this limitation or exclusion may not apply to you.

This Limited Warranty shall be the sole and exclusive remedy available to the PURCHASER with respect to this PRODUCT. In the event of any alleged breach of any warranty or any legal action brought by the PURCHASER, based on breach of warranty, alleged negligence or other tortious conduct by WARRANTOR, the PURCHASER's sole and exclusive remedy will be the repair or replacement of any defective PRODUCT as stated herein. In no event shall the liability of the WARRANTOR exceed the purchase price of the PRODUCT.

**Disclaimer**  
ANY IMPLIED WARRANTY OF MERCHANTABILITY OR FITNESS FOR A PARTICULAR PURPOSE AND ALL IMPLIED WARRANTIES ARISING FROM A COURSE OF DEALING, USAGE OF TRADE, BY STATUTE OR OTHERWISE, IS HEREBY STRICTLY LIMITED TO THE TERM OF THIS WRITTEN WARRANTY. This Limited Warranty shall be the sole and exclusive remedy available to the PURCHASER with respect to this PRODUCT. In the event of any alleged breach of any warranty or any legal action brought by the PURCHASER based on alleged negligence or other tortious conduct by WARRANTOR, the PURCHASER'S sole and exclusive remedy will be repair or replacement of defective materials or refund of the purchase price, as stated herein.

**Transfer of Limited Warranty**  
This warranty is made by WARRANTOR with only first PURCHASER of the PRODUCT and does not extend to any subsequent PURCHASER or any third parties. The unexpired portion of this Limited Warranty may not be transferred to any entity.

**Applicable Law**  
This Limited Warranty shall be deemed to have been particularly negotiated between parties. The parties expressly acknowledge and irrevocably agree that any and all claims or disputes arising out of or otherwise relating to this Limited Warranty shall be decided exclusively by Court of Milan under Italian Law with the exclusion of any courts of any

place. PURCHASER expressly waives any provision of law in the jurisdiction in which PURCHASER is located or any other potentially applicable law which conflicts with any provision of this Limited Warranty at any time.

**Other Rights**  
Your acceptance of delivery of The PRODUCT constitutes your acceptance of the terms of this Limited Warranty. This Limited Warranty gives you specific legal rights, and you may also have other rights which vary from state to state. If any term or provision of this Limited Warranty is invalid or unenforceable under any local, state, or federal law, statute, judicial decision, regulation, ordinance, executive order or other rule of law, such term shall be deemed reformed or deleted, but only to the extent necessary to comply with such statute, regulation, ordinance, order or rule and the remaining provisions of this Limited Warranty shall remain in full force and effect.

**Entire Agreement**  
This document alone contains the entire Limited Warranty given by WARRANTOR in respect of the PRODUCT. Nothing in WARRANTOR's product literature, marketing materials, advertisements and technical specifications expand or enlarge the scope of this Limited Warranty. There are no terms, promises, conditions or warranties regarding the PRODUCT other than those expressly contained herein. WARRANTOR specifically does not authorize any person, including but not limited to any dealer or other agent or employee of WARRANTOR, to extend the time, scope, terms or conditions of this Limited Warranty or to create or assume for WARRANTOR any other obligation or liability with respect to the PRODUCT or other products designed, manufactured or sold by WARRANTOR. All terms of this Limited Warranty are contractual and not mere recitals, and constitute material terms of this Limited Warranty. It is agreed and acknowledged that the provisions of this Limited Warranty allocate the risks between WARRANTOR and PURCHASER, that WARRANTOR's pricing reflects this allocation of risk, and but for this allocation and limitation of liability, WARRANTOR would not have entered into this Limited Warranty.

The agents, employees, and dealers of WARRANTOR Products are not authorized to make modifications to this limited warranty or make additional warranties binding on the WARRANTOR.

THIS DOCUMENT AND ALL PROVISIONS CONTAINED HAS BEEN SPECIFICALLY AGREED BETWEEN THE PARTIES.

Head offices & showroom

Lodes, via Pialoi 32,  
30020 Marcon (Venezia) Italy  
T +39 041 45 69 266

General information  
info@lodes.com

2023 Preview

*Art direction  
and graphic design*  
Think Work Observe

*Images*  
Bruger Studio

*Copywritings*  
Lodes

*Colour separation  
and printing*  
Grafiche Antiga

Lodes Milan showroom

via della Moscova 33,  
Cortile della Seta  
20121 Milano (MI) Italy  
T +39 02 4940 0999  
milano@lodes.com

Lodes Flagship

Paris  
Novaluce S.a.r.l.  
131 Rue du Faubourg  
Saint-Honoré  
75008 Parigi, Francia  
T +33 142 890 318  
paris@lodes.com

Doha  
Abensal Lighting  
C-Ring Road, St. 230  
Zone 41, Building no. 245  
Al Hilal – Doha, Qatar  
T +974 4016 4866  
qatar@abensal.com

2023 Preview  
lodes.com